

TWO COUNTERBALANCE MONITOR ARM

www.ctfconsoles.com

CTF-MA-02

The **CTF-MA-02** is a counterbalance monitor arm designed for 13" to 32" flat or curved LCD/LED monitors, optimizing console space and enhancing flexibility and productivity in the workspace.



Screen Size
13"-32"



Weight Capacity
1-9kg (x2nos)



Tilt Range
+90° ~ -45°

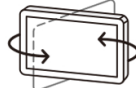

Swivel Range
+90° ~ -90°



Screen Rotation
360°



Cable Management

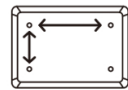

VESA Compatible
75x75 100x100



Curved Monitor

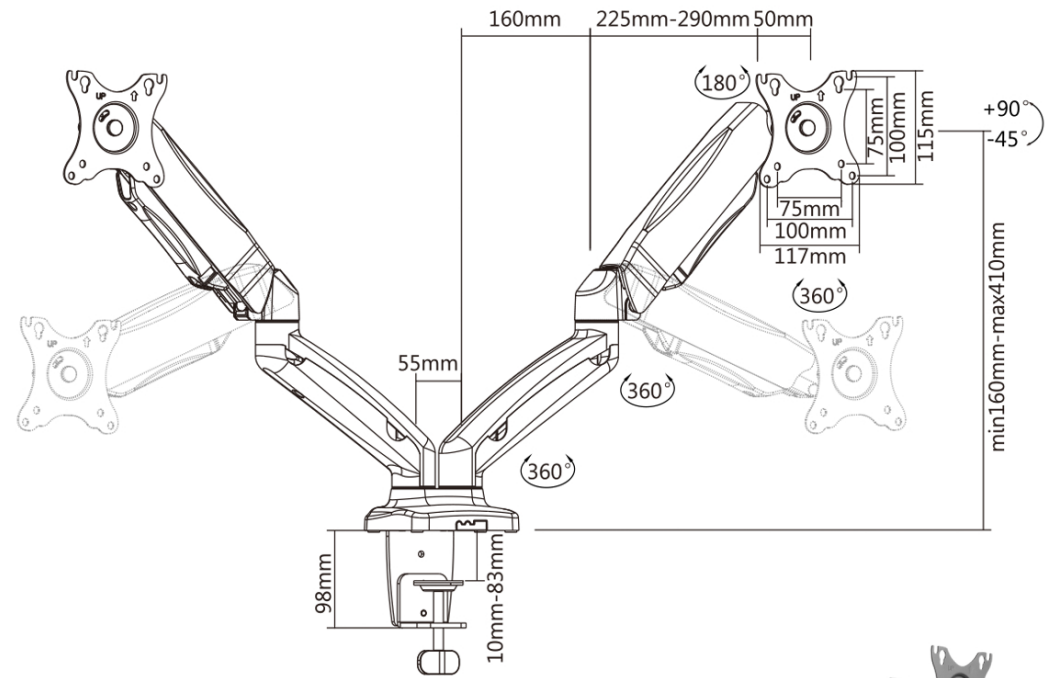

Pear-shaped VESA Slot makes the installation much easier by one-step slide-in.

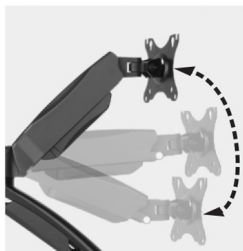

Gas Spring Counterbalance floats the monitor with a light touch for a customized placement to match your viewing needs anytime.



Built-in Spring Gauge can be adjusted to suit various monitor weight.

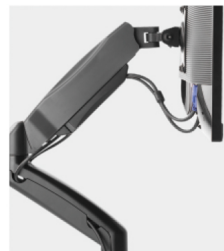

Cable Management routes cables under the arm to reduce clutter for a clean look.



2.0 USB Port and Audio Port in the Basement are convenient for supporting data transfer, charging and sound input/output.



Grommet/Desk Mount Base suits most desks with adjustable clamp height.



CTF-MA-S32

The **CTF-MA-S32** is a premium counterbalance monitor arm with a durable gas spring aluminum design, compatible with most 17" to 32" flat and curved monitors.

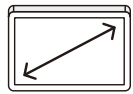

Screen Size
17"-32"

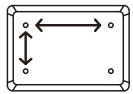

VESA Compatible
75x75 100x100



Weight Capacity
1.5-8kg (x2)



Tilt Range
+45° ~ -45°

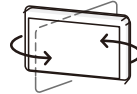

Swivel Range
+90° ~ -90°

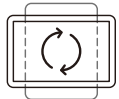

Screen Rotation
+180° ~ -180°

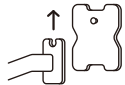

Detachable
VESA Plate

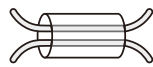

Cable
Management



Curved Monitor

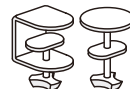

Clamp & Grommet
Installation

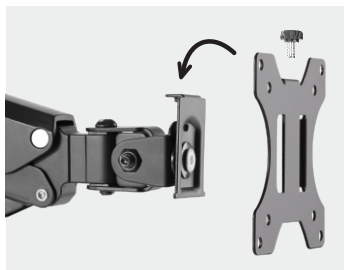
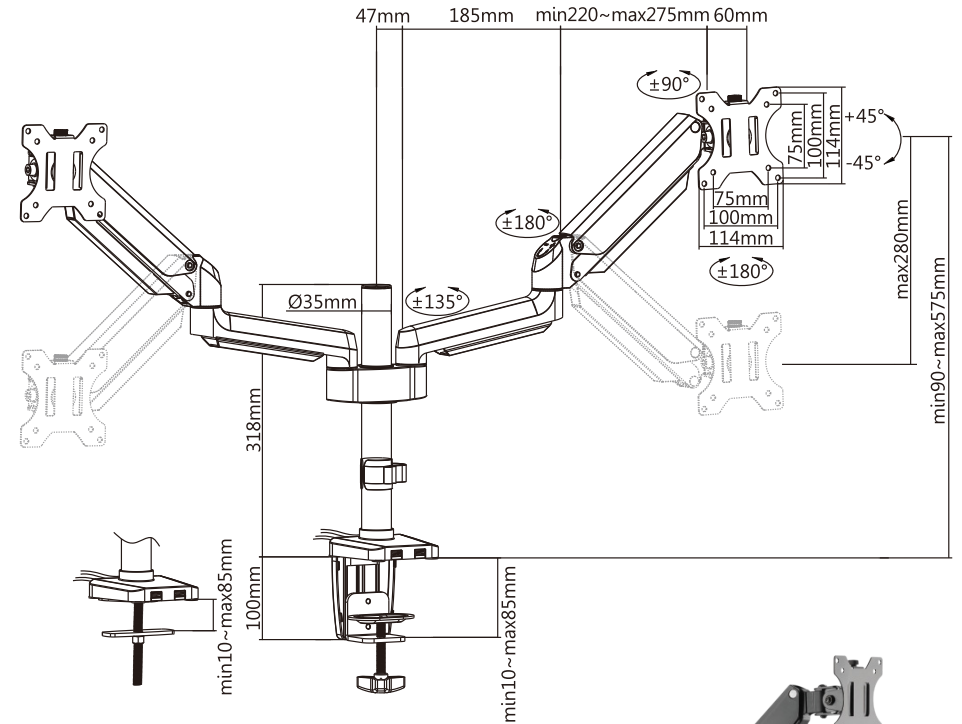

Detachable VESA Panel
makes installations quick easy.

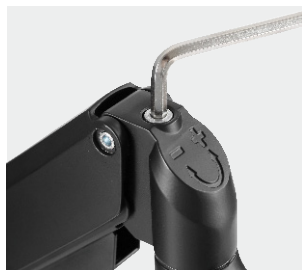

**Adjustable Gas Spring
Tension**
able to bear most types of
monitor.

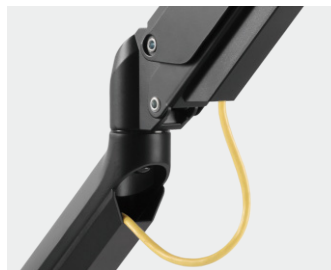

Built-in Cable Management
create a clean look by
eliminating cable clutter.



Clamp & Grommet Installation
accommodate more users.





CONNECTED TECHNICAL FURNITURE

CTF Metal Steel Workshop LLC

Warehouse B3, Dubai Investment Park-1, Dubai, United Arab Emirates

 www.ctfconsoles.com

 CTF Consoles

 hello@ctfconsoles.com