

ONE COUNTERBALANCE MONITOR ARM

www.ctfconsoles.com

CTF-MA-HD01

The **CTF-MA-HD01** is a heavy-duty counterbalance monitor arm designed for 17"-49" flat or curved monitors, offering a perfect blend of health, convenience, and style. With easy topside installation and integrated cable management, it ensures a clean, organized workspace without the hassle of crawling under desks.

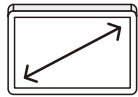

Screen Size
17"-49"

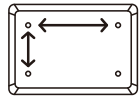

VESA Compatible
75x75 100x100

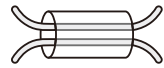

Cable Management



Weight Capacity
2-20kg/4.4-44lbs



Tilt Range
+50° ~ -20°



Curved Monitor

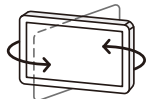

Swivel Range
+90° ~ -90°

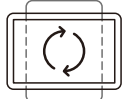

Screen Rotation
+180° ~ -180°

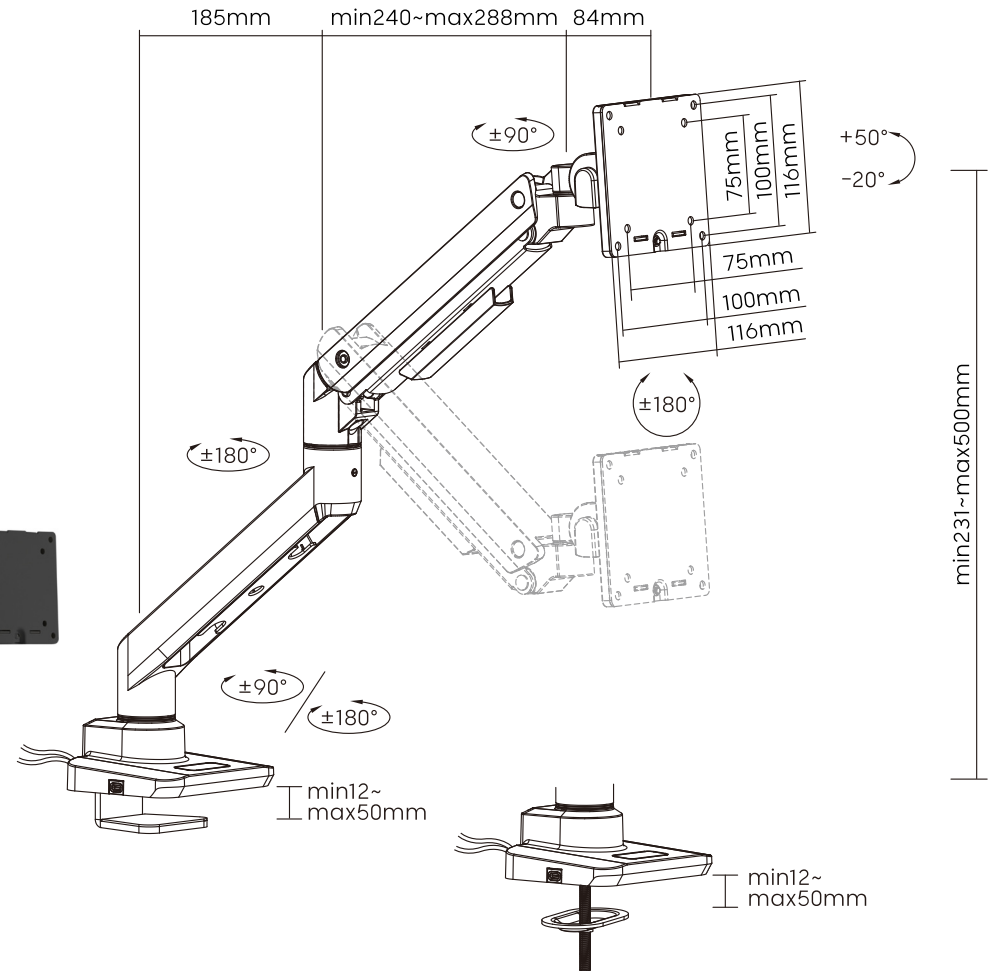
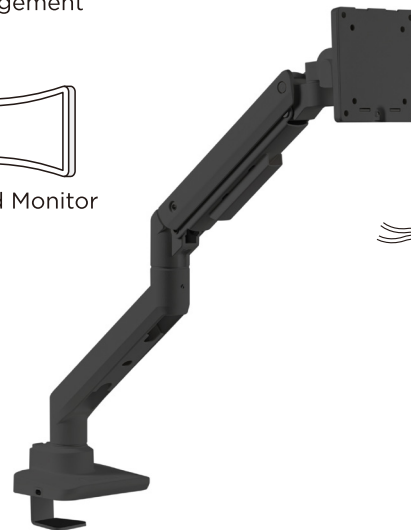



CONNECTED TECHNICAL FURNITURE

CTF Metal Steel Workshop LLC

Warehouse B3, Dubai Investment Park-1, Dubai, United Arab Emirates

 www.ctfconsoles.com

 [CTF Consoles](#)

 hello@ctfconsoles.com